



2009 OWNER'S MANUAL

Villa

Manufactured after December 22, 2009
© 2009 Lloyds Material Supply, Inc.



Cal Spas Home Resort™

www.calspas.com

LTR20091034, Rev. A
12/16/08

Delivery and Set-Up

Planning the Best Location for Your Villa.	1
Preparing a Good Foundation	1
Size Specifications	1

Villa Assembly

Column Placement.	2
Anchoring the Main Support Post.	2
Roof Assembly	5

Appendix

Cleaning	6
Maintenance	6
Warranty Information.	6

Read This First!

Carefully read and follow all safety instructions.

When installing and assembling your villa, it is recommended that two or more people be involved.

Do not use the unit during an electrical storm.

Do not climb on top of the villa. While the villa is made out of high-quality material and is extremely durable, it is not meant to support weight. In addition, falling off of the villa while climbing on it can result in serious injury or death.

Do not attempt any repair without consulting the manufacturer first. Unauthorized repairs will void the manufacturer's warranty (within the first 90 days).

Copyright 2008-2009 LMS, Inc. All rights reserved. Duplication without written consent is strictly prohibited.

Cal Spas™ and Cal Enclosures™ are registered trademarks.

Due to continuous improvement programs, all models, operation, and/or specifications are subject to change without prior notice.

LTR20091034, Rev. A
12/16/08

CONTACT INFORMATION

For customer service, please contact your authorized dealer immediately. If you need additional information and/or assistance, please contact:

LMS Customer Service Department
1462 East Ninth Street
Pomona, CA 91766.

Toll Free: 1-800-CAL-SPAS
Fax: 1-909-629-3890

Planning the Best Location for Your Villa

Most cities and counties require permits for exterior construction and electrical circuits. In addition, some communities have codes requiring residential barriers such as fencing and/or self-closing gates on property to prevent unsupervised access to the property by children under the age of five. Your dealer can provide information on which permits may be required and how to obtain them prior to the delivery of your equipment.

The following are some of the things that you will need to consider when determining the placement of your new villa.

Consider How You Will Use Your Villa

How you intend to use your villa will help you determine where you should position it. For example, will you use your villa for recreational purposes? If your villa is mainly used for family functions, be sure to leave plenty of room around it for activity.

Consider Your Privacy

In a cold weather climate, bare trees won't provide much privacy. Think of your villas surroundings during all seasons to determine your best privacy options. Consider the view of your neighbors as well, when you plan the location of your villa.

Provide A View With Your Villa

Think about the direction you will be facing when sitting in your villa. Do you have a special landscaped area in your yard that you find enjoyable? Perhaps there is an area that catches a soothing breeze during the day and lovely sunset in the evening. Consider these things when you plan your location.

Preparing a Good Foundation

Your villa needs a solid and level foundation. The area that it sits on must be able to support the weight of the villa and the occupants who use it. If the foundation is inadequate, it may shift or settle after the villa is in place, causing stress that could DAMAGE YOUR VILLA.

Place the villa on an elevated foundation (preferably a 3" concrete slab). Be sure that the concrete slab is at least 12" wider than the outside dimension on the villa.

- If you are installing a spa or villa on an elevated wood deck or other structure, we strongly recommend that you consult a structural engineer or contractor to ensure the structure will support the weight of 150 Lbs./ sq. ft.
- It is strongly recommended that a qualified, licensed contractor prepare the foundation for your villa.

Size Specifications

Length	Width
12'	12'
12'	16'
14'	14'
14'	18'
16'	16'

NOTE: We recommend that the foundation extend beyond the dimension of the villa. For example, if the villa you purchased is 12'x12', you will want your foundation to be 12'x12'. The reason for this is because it will be easier to maintain the area around the villa (mowing the lawn, edging, etc.) without damaging or scarring the villa. Also, in doing this, you will eliminate any potential problems, foundation-wise, in the future.

NOTE: This owner's manual applies to the various sizes that are included in the villa line. While the sizes will vary from villa to villa, the assembly instructions will be the same, unless otherwise noted.

Villa Assembly

Column Placement

Reference your column placement chart for the particular villa you purchased. The center point measurements will be described for your particular sized villa. Please locate these dimensions and mark them on your floor or professionally laid slab. If your municipality requires a footing please see our recommendations for proper column installation.

Anchoring the Main Support Post

When scoring the concrete, make sure that the mark is dark enough to see, as you will be drilling a hole in the concrete. This hole will be where the anchoring bolt is located. Also, it is the owner's responsibility to obtain a 1/2" masonry bit. This bit will be used to drill the anchoring holes in the foundation. A masonry bit may be bought at any local hardware store.

Refer to Figure 1 for steps 1 through 3.

1. Pre-drill the anchoring hole using a 1/2" masonry drill bit (see NOTE above). Drill the hole to a depth of no less than 3". Using a hammer, insert the anchoring bolt by gently tapping the bolt into place. Continue to tap into place until the anchoring bolt is seated securely in the hole.
2. After drilling the hole and inserting the anchoring bolt, slide the main support post assembly on to the anchoring bolt and tighten down using the provided hardware.
3. Repeat these steps for all four corners of the villa.

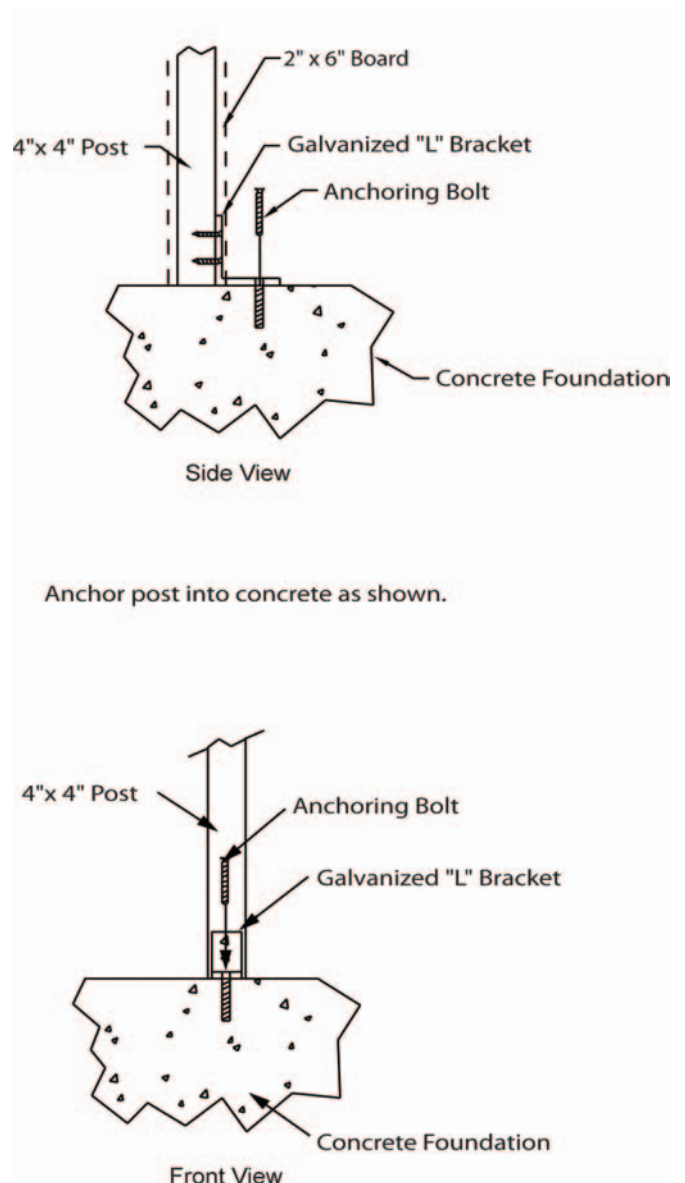

Figure 1. Anchoring the main support post

The final placement of the main support posts is shown in Figure 2. The main support posts should be mounted no less than 1" from the side of the spa. If the villa is touching the spa, and any damage is incurred due to contact, the warranty on the spa siding is void.

The total distance between each main support post will be determined by the size of the spa and villa that was purchased. The list below will tell you what each distance should be for each model:

If the spa is:	The distance between each villa main support post is:
7' x 7'	± 7' - 2" x 7' - 2"
7.5' x 7.5'	± 7' - 8" x 7' - 8"
8' x 8'	± 8' - 2" x 8' - 2"

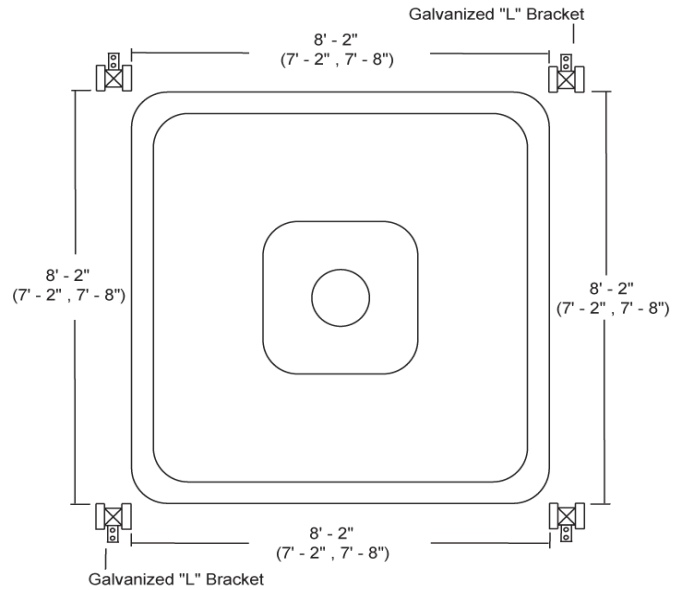
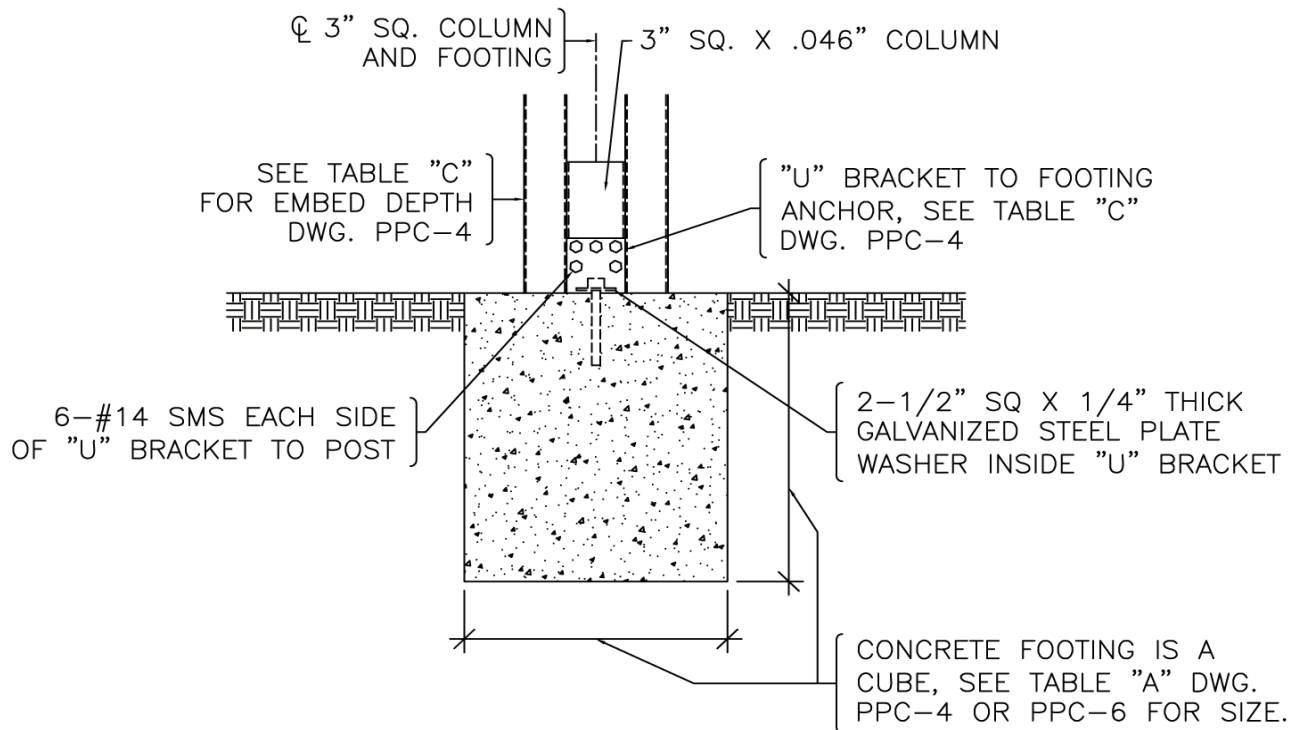
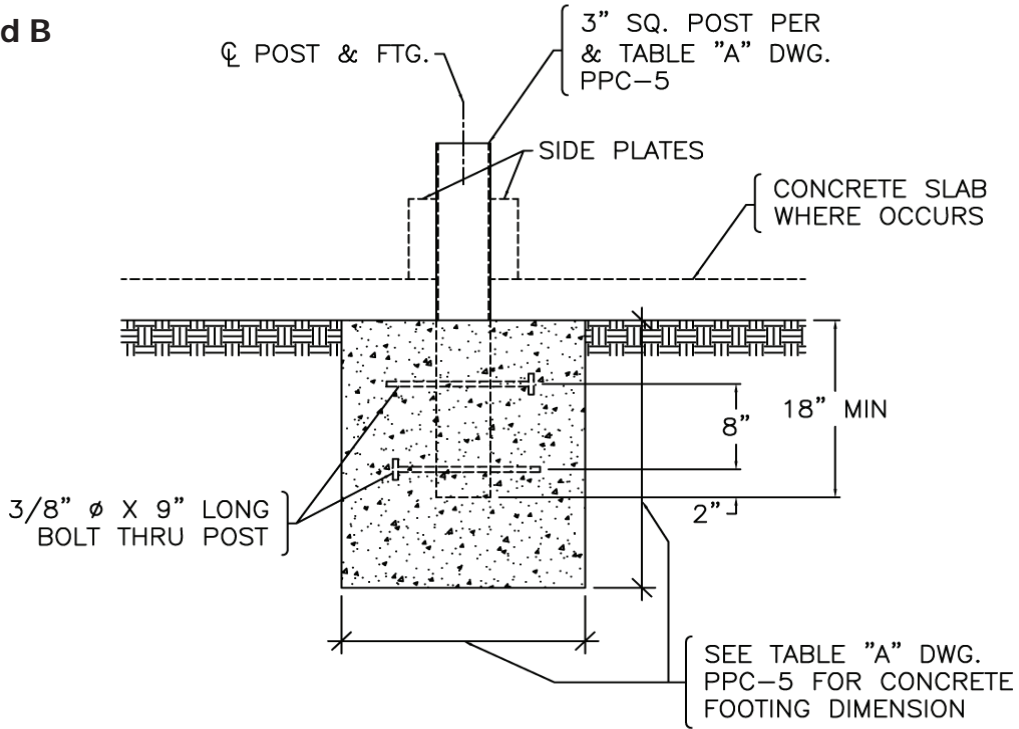

Figure 2. Placement of the support posts

Method A



Method B



Method C

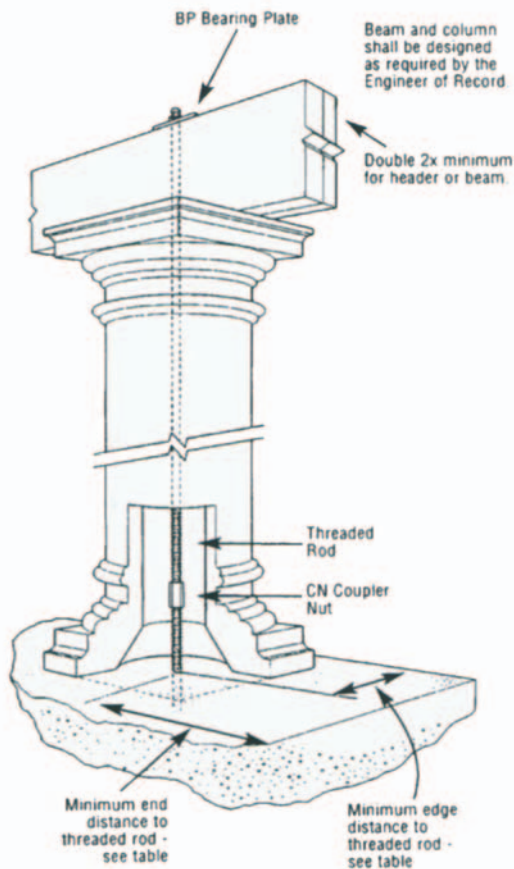

Roof Assembly

USE HARDWARE TO ATTACH BRACKET TO BEAMS
EVENLY SPACE BRACKET
BEAMS MUST BE LEVEL
1/4" x 2-1/2"
BEAMS.
SCREW CAPS
DECORATIVE COLUMN COVER NOT SHOWN FOR CLARITY

**BRACKET TO BEAM
ASSEMBLY INTRUCTIONS
STEP #2**

4.50" ON CENTER TUBE OR PER CUSTOMER SPEC.
1/4" x 2-1/2"
BEAMS.
DECORATIVE COLUMN COVER NOT SHOWN FOR CLARITY

**2" TUBING TO BEAM
ASSEMBLY INTRUCTIONS
STEP #4**

DECORATIVE CAP COVER WILL SLIP OVER COLUMN
CAP
BEAMS MUST BE LEVEL
3/8" x 1"
USE HARDWARE TO ATTACH BEAMS TO POST AS SHOWN
DECORATIVE COLUMN COVER NOT SHOWN FOR CLARITY
2.00"
2.00"
5/8" DIA. 4 PLACES TOP.
USE 3/8" BIT TO ASSEMBLE

**BEAM TO POST
ASSEMBLY INTRUCTIONS
STEP #1**

24" O.C.
12" O.C.
1/4" x 1/2" W/WHITE HEAD
BEAM
USE HARDWARE TO ATTACH BRACKET TO BEAMS AS SHOWN
DECORATIVE COLUMN COVER NOT SHOWN FOR CLARITY

**BEAM TO BRACKET
ASSEMBLY INTRUCTIONS
STEP #3**

24" O.C.
12" O.C.
ONLY FIRST BEAM
COLUMN AND TUBING
ASSEMBLY INTRUCTIONS

COLUMN
U-BRACKET SUPPLIED
USE 3/8" BIT TO ASSEMBLE

**U-BRACKET DETAIL
ASSEMBLY INTRUCTIONS**

Appendix

Cleaning

Your villa was designed with low cleaning and maintenance in mind. We recommend that the surround package be cleaned at least twice a month (or more, if needed). When cleaning your villa, do not use cleaning solvents -- using a sponge and water will be fine. For ground-in dirt and grime, refer to the following section.

Maintenance

Maintaining your villa is an easy task. We recommend that every six months you inspect your surround package. Take note of any deformities in the wood (i.e. cracking, peeling, dirt, grime, etc.). Wipe the stained area clean and reapply until the sanded area matches the rest of the villa.

Warranty Information

See your Cal Enclosures villa dealer for a copy of the applicable warranty, details and any questions you may have regarding the warranty coverage on your villa.

Warranty Limitations

The Limited Warranty is void if the villa has been subject to negligence, alteration, misuse, abuse, repairs by non-LMS authorized representatives, acts of God and any other cases beyond the control of LMS. Examples of common acts invalidating this warranty include but are not limited to:

- Use of the villa in a non-residential application
- Scratches caused by normal use
- Damage caused by extreme weather conditions (heat, cold, etc.)
- Damage caused by dirt, sand, and/or water damage
- Damage caused by direct sunlight
- Damage caused as a result of failure to follow the assembly instructions as defined in this owner's manual

This Limited Warranty applies only to villas normally used for personal, family, or household purposes.

This Limited Warranty is obsolete 90 days after the original purchase date.

Warranty Exclusions

LMS warrants the villa from defects in material and workmanship for a period of 90 days from the original date of purchase.

DON'T FORGET TO REGISTER YOUR NEW PRODUCT AT WWW.CALSPAS.COM.

CONTACT INFORMATION

For customer service, please contact your authorized dealer immediately. If you need additional information and/or assistance, please contact:

LMS Customer Service Department
1462 East Ninth Street
Pomona, CA 91766.

Toll Free: 1-800-CAL-SPAS
Fax: 1-909-629-3890

Villa Model: _____

Villa Serial Number: _____

Date Purchased: _____

Date Installed: _____

Cal Spa Dealer's Phone Number: _____

Cal Spa Dealer's Address: _____